

# Recording FORMATS

ALEXA MINI LF

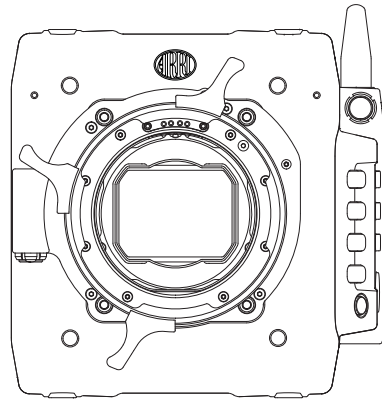

## Truly cinematic. Truly flexible.

ALEXA Mini LF is incredibly flexible: one camera with a multitude of sensor modes that allow you to choose different looks, lenses, aspect ratios, and deliverables for different projects. Six new sensor modes are provided for free through software update SUP 7.1.

### 4.5K LF 3:2 Open Gate

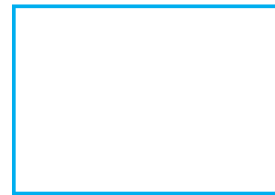

**4.5K**  
ARRIRAW **40 fps**  
Apple ProRes **40 fps**

### 4.5K LF 2.39:1

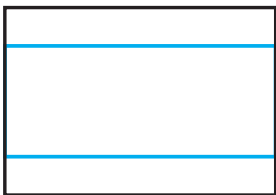

**4.5K**  
ARRIRAW **60 fps**  
Apple ProRes **60 fps**

### 4.3K LF 16:9

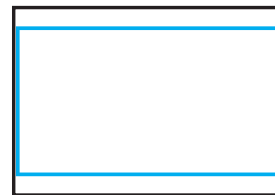

**UHD**  
Apple ProRes **48 fps**  
**HD**  
Apple ProRes **75 fps**

### 3.8K LF 16:9

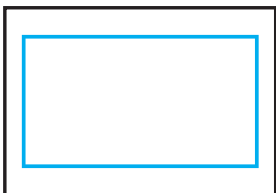

**UHD**  
ARRIRAW **60 fps**  
Apple ProRes **60 fps**  
**2K**  
Apple ProRes **90 fps**  
**HD**  
Apple ProRes **90 fps**

### 2.8K LF 1:1

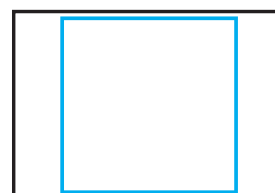

**2.8K**  
ARRIRAW **60 fps**  
Apple ProRes **60 fps**

### 3.4K S35 3:2

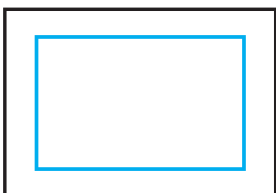

**3.4K**  
ARRIRAW **60 fps**

### 3.2K S35 16:9

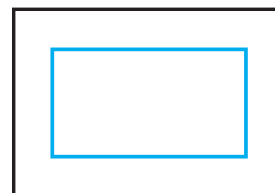

**3.2K**  
Apple ProRes **75 fps**

### 2.8K S35 4:3

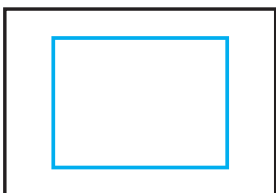

**2.8K**  
Apple ProRes **75 fps**

### 2.8K S35 16:9

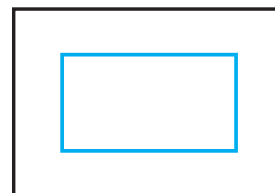

**HD**  
Apple ProRes **100 fps**