



Operating Instructions

Electronic Ballast

2,5/4 EB

DMX

- flicker free -

**Arnold & Richter Cine Technik
Lighting Division
Pulvermühle
D-83071 Stephanskirchen
Tel. (0)8036-3009-0
Fax (0)8036-2471**

L2.76646.0

Contents	Page
1. General Remarks	3
2. Important Safety Instructions	3
3. Product Description.....	5
4. Start-Up Procedure.....	5
4.1 Energizing System	5
4.2 Control of Light Intensity	6
4.3 Reduction of Lamp Noise	6
4.4 Remote Control DMX-512.....	6
4.5 Selection of Device Address.....	6
5. Technical Data	7
6. Trouble Shooting Guide.....	8
7. Connector Wiring.....	9
8. Operating Parts on Front Panel.....	10

OPERATING INSTRUCTIONS

Electronic Ballast ARRI 2,5/4 EB

1. General Remarks Please read the following operating instructions very carefully before using the Electronic Ballast (EB) the first time. They contain important information and instructions for the safety, use and maintenance of the appliance. For your own safety please follow all safety instructions and warnings. Keep the operating instructions carefully in a safe place and pass them to any future owner.

2. Important Safety Instructions

2.1 Warning - High voltages inside ballast ! Danger to life !

Disconnect EB from power supply before opening (pull out the line plug). Do not pull on the connection cable, but on the plug, to disconnect the EB from mains. Any repairs or changing of the line plug must only be carried out by qualified personnel or ARRI-service departments.

2.2 The standard European line plugs are only permissible for use on 220 ... 250 V supplies. For 100 ... 120 V supplies line plug has to be changed to a plug with protective earth which is suitable for the higher current (see max. current in "Technical Data", page 7). When making connections be sure that the earth conductor is made longer than the live or neutral conductors. This means that if the cable is strained the earth conductor will be the last to be disconnected and so you will not be electrocuted.

Before connecting the Electronic Ballast ensure that the power supply is correctly wired. Do not use without adequate earth connection unless either an isolation transformer or an earth-leakage trip is employed.

Note: In order to avoid unwanted tripping due to leaking currents and transient disturbances, care shall be taken that the collective leakage current of equipment on the load side of a residual current device is less than 1/3 of its rated residual current.

The typical leakage current of this device is 3.4 mA (according EN 60598-1:1996, appendix G).

2.3 Lamphead must be disconnected from Electronic Ballast or Electronic Ballast must be disconnected from mains before fitting or replacing a lamp.

2.4 The Electronic Ballast must be switched off before connecting or disconnecting either head or supply cable. Do not use other than original ARRI cables and connector with permitted cross section of the leads. The ballast is only suitable for specified ARRI luminaires (see fig. 1a + 1b, page 9). Using other than original ARRI cables or luminaires may cause injury to the user as well and/or damage to the ballast.

2.5 The Electronic Ballast satisfies the standards of the recognized state of the engineering and the pertinent safety regulation of DIN EN 60598/1 and DIN EN 60065 for electrical appliances.

2.6 Supply voltage must not exceed the ranges that are given in the "Technical Data" (see page 7). Check that the power supply voltage and wiring are suitable for the ballast to be used. Supply voltages which are greater or less than that specified for the ballast can cause injury to the user as well as damage to the ballast.

The electronic of the EB is built in a housing with protective class I and protective rate IP 22.

Ambient operating temperatures must be between -20°C and + 50°C!

Neither heat sinks nor air slots for ventilation should ever be covered or obstructed.

The EB must be placed only on solid, flat and dry ground. Temperature of the ground should be less than 50°C. If the EB could slip over the ground, it must be fastened.

Protect EB against direct sunshine. Protection against rain is needed when wind pushes water drops direct into the air slots of the EB (acc. to protective rate IP 22).

Do not operate the EB in high humidity (dew) or in aggressive or explosive gas-air mixtures.

2.7 The Electronic Ballast must be used only according to the directions in this "Operating Instruction". The manufacturer shall not be liable for any damages caused by unintended use or wrong operation.

2.8 The user of the Electronic Ballast is urgently requested to observe the following instructions:

- Dispose of packing material properly.
- Do not place the ballast into operation if damages are apparent.
- To assure safe operation, use EB only according to the information given in these operating instructions, connect and operate it as shown on the serial number plate.
- In case of malfunction, disconnect the EB from mains (pull out the line plug).
- Repairs, exchange of replacement parts and manipulations on the EB must be carried out by a qualified personnel or ARRI service only.
- Use only original spare parts for repairs.
- Use only original accessories.
- Make worn-out Electronic Ballasts inoperable immediately by pulling out the lineplug and cutting the line cable at the ballast. Then dispose of the Electronic Ballast properly.
- Make sure that children do not operate the EB.
- Always switch off the EB and pull out line plug before you clean it or do maintenance work on it.
- Clean EB dry only or with a moist cloth. Never immerse it into water.
- Do not use the connection cables of the EB for carrying, do not pull them over sharp edges, clamp them under doors or clamp them in any other way.
- Switch off EB when it is not needed.

3. Product Description The ARRI 2,5/4 EB is part of an optimized lighting system along with all ARRI 2500W and 4000W luminaires specified for operation with the EB (see fig. 1a + 1b, page 9). It is suitable for both professional indoor and outdoor use (IP22 protection).

Compared to magnetic ballasts there are a number of advantages when operating daylight-lamps with ARRI Electronic Ballasts:

- Flicker free light
- No synchronization of cameras necessary
- Typical lighttripple max. 3 %
- Light intensity increased by at least 5 %
- Constant lamp power
- Constant color temperature
- Constant light quality
- Control of electric power of the lamp between 50...100%
- Variation in power supply voltage of 10% has no influence on the power of the lamp (see also "Technical Data" for limits, on page 7).
- Variation in power supply frequency of 10% has no influence on the power of the lamp
- Operating life time of the lamp increased by at least 20%
- Substantially less volume and weight compared to magnetic ballasts
- The ballast is built-in to a casing with type of protection IP22.

4. Start-up procedure All operating controls and cable connections are arranged on the front panel (see fig. 2, page 10).

4.1 Energizing System

- Check ON/OFF Switch to be in "OFF"-position.
- Connect the properly checked daylight luminaire with head to ballast cable to electronic ballast
- Connect the electronic ballast to the power supply source.
- Ensure main circuit breaker is in "ON" position
- The green LED "POWER" on front plate is lit when Line Voltage is applied and the Main Circuit Breaker is in "ON" position.
- Check earth protection: If correct, the green LED "PE" on front plate illuminates. If not, disconnect EB from mains (pull out line plug) and check power supply and socket (Ref. 2.2. on page 3)
- Set ON/OFF Switch to "ON"-position as well on the EB as on the head. Lamp will ignite after about 5 sec.
- The yellow LED "LAMP" on front plate is lit after successful ignition.

4.2 Control of light intensity

After warming up, the light intensity of the metal halide daylight-lamp may be controlled by the dimming potentiometer (stepless). The nominal lamp power can be adjusted between 50 - 100% (left stop = MIN, right stop = MAX of power).

4.3 Reduction of lamp noise

When metal halide daylight lamps are operated in the *flicker free* mode some noise might occur, due to the special square-wave operation of the lamp.

1. In the position *flicker free* (green LED indicating light) the electronic ballast will operate *flicker free*, the lamp gives out a constant light.
2. In the position "50 Hz" or "60 Hz" (red LED indicating light) noise will be substantially reduced, the amount depending on the lamp, in some cases even to almost zero.

The light, however, is **NOT** flicker free any more.

When operating in this mode, the same limitations for speed of camera and/or shutter angle apply as for magnetic ballasts. All other advantages of the electronic ballast will apply as before!

If in doubt (i.e. remote from ballast) with the flicker analyzer P.R.O.F light can be checked to be flicker free or not.

4.4 Remote Control DMX-512

Switching the Ballast on/off and dimming of lamp power can be controlled by a remote control according DMX-512 standard.

One channel is used for dimming the ballast, the second channel is used for switching the ballast on and off. The address of the dimming channel is indicated by the LED display at the front plate of the ballast. The address for the on/off channel will be the dimming address incremented by one. To switch the ballast 'on' a value between 128 and 255 must be send to this address. A value of 0 .. 127 will cause the ballast switching off.

Dimming is done by sending a value between 127 and 255 to the dimming address which will correspond to lamp power regulated between 50% (127) to 100% (255) of the nominal value.

To control the ballast via remote it is necessary that it was switched on by remote. In this case the dimming potentiometer on front plate of the ballast has no function!

Attention: The potential of the remote control signals at the connectors may not exceed 70 Volts (peak) against protective earth.

4.5 Selection of Device Address

At the upper part of the front panel is a LED Display which indicates the current address of the ballasts **dimming channel**. The "UP" and "DOWN" keys can be used to change the displayed address. To take over the new address, the "ENTER" key has to be pressed.

The green LED "DMX" indicates that DMX signals are received at the adjusted channel (dimming) and at the next channel (switching).

5. Technical Data

Mains supply

Line Power	:	6200 VA (max.)
Supply Voltage	:	90 - 125 V / 190 - 250V~ 50/60 Hz 1, N, PE
Nominal Current	:	69 - 50 A / 33 - 25 A
Power Factor	:	cos φ \approx 0.7

Lamp connection

Lamp Power	:	2500 W / 4000 W constant control
Current Characteristic	:	square wave, 75 Hz
Dimming	:	Range 50 - 100% of nominal Lamp power
Starting	:	cold start and hot restrike
typical light ripple	:	typ. < 3%

Dimensions

width · height · depth	:	243 · 358 · 450 mm
Weight	:	approx. 20 kg
Protective Rate	:	IP 22

6. Trouble Shooting Guide

6.1 Does supply voltage correspond with ballast required voltage? Dual voltage ballasts are autoswitching.

6.2. Ensure ballast wattage matches lamp power!

6.3 Ensure correct lamp is fitted!

6.4 Connect ballast to power supply and test earth.

6.5 Re-energizing system:

Ensure ON/OFF Switch is in "OFF" position.

Switch ON/OFF switch to "ON". Switch should now illuminate. - WAIT-

After approx. 5 seconds lamp should ignite.

6.6 If lamp does not strike, the safety circuit may be broken - check if lens door is fully shut and the lens safety switch is activated.

6.7 Is there a good power supply to the ballast?

6.8 Is the ballast main circuit breaker in ON position?

6.9 If a ballast / head to ballast cable / luminaire does not work then all three units should be considered faulty.

Do not try a suspected luminaire with another ballast - you may end up with two faulty ballasts!

To check if a ballast is good, run it with a known good luminaire and known good head to ballast cable.

6.10 If a ballast cuts out after running a few minutes there are a number of possible failures:

- The lamp itself may be faulty or at the end of its life.
- The thermal cut-out in the ballast may have activated due to extreme ambient temperature or exposure to direct sunlight in hot summer conditions (LED "TEMP" on front plate is lit).
- The ventilation might be restricted. In such a case the ballast can be used after it had cooled down and the condition causing the overheating is removed.
- If the power supply exceeds the limits or has spikes or drop-outs the ballast switches off to protect itself. If running on a generator the output should be regulated between 95 - 120 V / 195 - 245V.
- If a ballast has cut off due to a momentary supply drop-out switch the ballast "OFF" and "ON" again. The ballast should start up as normal.
- Earth leakage of luminaires or head to ballast cables will also cause the protection circuit to be activated. Test the ballast with a known good luminaire. If cables are suspect, they should be exchanged with known good cables.

If a ballast is found to be faulty ideally it should be returned together with the luminaire and head to ballast cable to the ARRI-service location for examination.



Abb./Fig. 1a: Elektronisches Vorschaltgerät mit Scheinwerfer
Electronic Ballast with Lamp Unit



Abb./Fig. 1b: Elektronisches Vorschaltgerät mit Scheinwerfer
Electronic Ballast with Lamp Unit

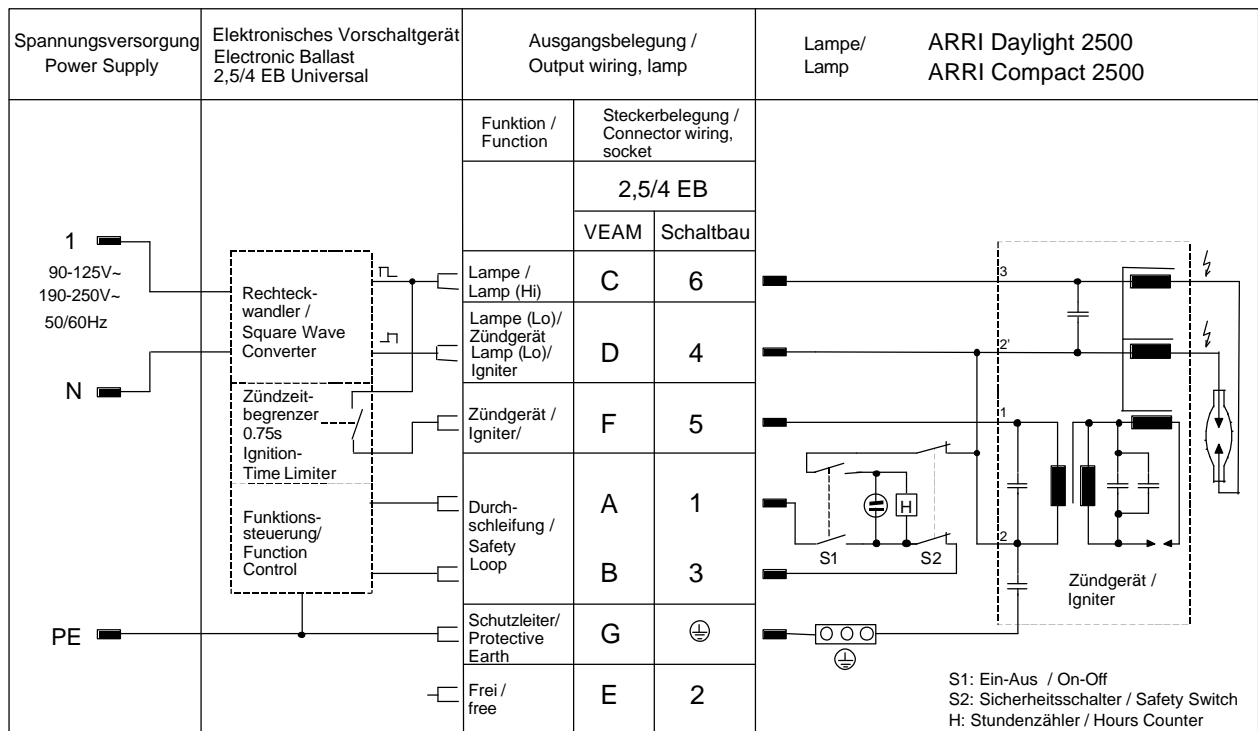
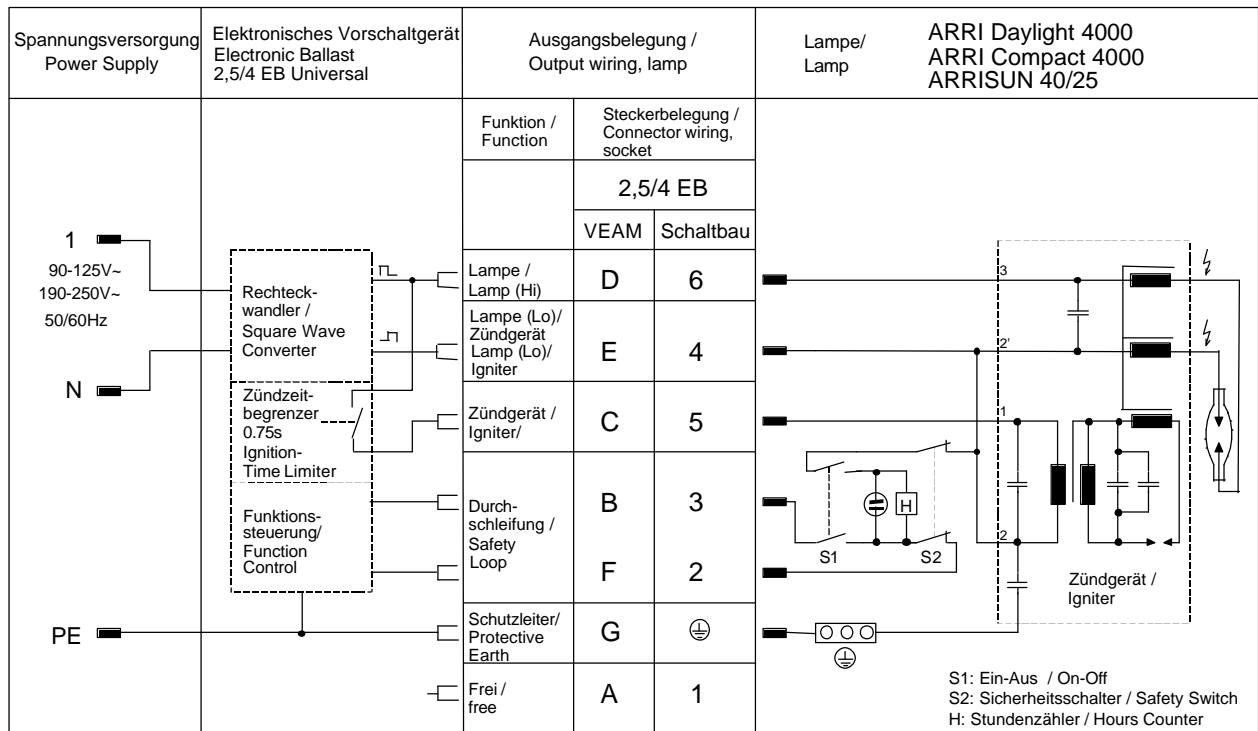
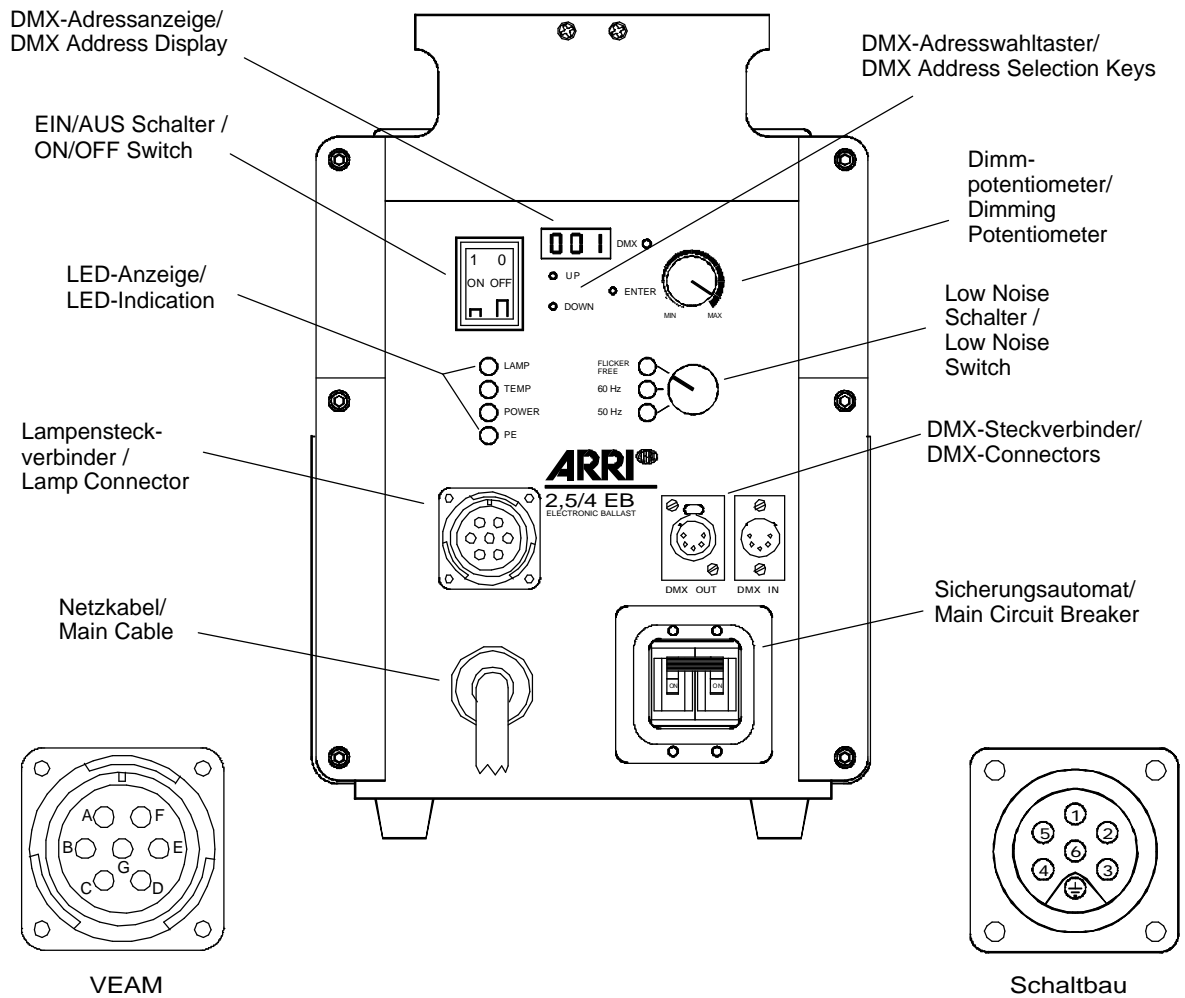

Abb./Fig. 2: Bedienelemente auf der Frontplatte
Operating Parts on Front Panel