



# AMC-1

## Active Motor Controller

User Manual



# Imprint

## Copyright

Copyright © 2015 ARRI Cine + Video Geräte Gesellschaft m.b.H. (ARRI). All rights reserved. No portions of this document may be reproduced without prior written consent of ARRI Cine + Video Geräte Gesellschaft m.b.H. Specifications are subject to change without notice. Errors, omissions, and modifications excepted.

ARRI, ALEXA, LDS and LENS DATA SYSTEM are trademarks or registered trademarks of Arnold & Richter Cine Technik GmbH & Co. Betriebs KG. All other brands or products are trademarks or registered trademarks of their respective holders and should be treated as such.

Original version.

## For further assistance

ARRI Cine + Video Geräte Gesellschaft m.b.H.

Pottendorferstraße 23-25/3/2/1

1120 Vienna, Austria

E-mail: [service@arri.com](mailto:service@arri.com)

[www.arri.com](http://www.arri.com)

## Scope

This instruction manual applies to the following product: Active Motor Controller AMC-1 with Software Update Package (SUP) 1.23 onwards.

## Revision history

<b>Version</b>	<b>ID</b>	<b>Release</b>	<b>Date</b>
1.0	10001153	F05821	10.08.2015

## Disclaimer

Before using the products described in this manual be sure to read and understand all respective instruction.

The ARRI Active Motor Controller AMC-1 is only available to commercial customers. The customer grants by utilization that the AMC-1 or other components of the system are deployed for commercial use. Otherwise the customer has the obligation to contact ARRI preceding the utilization.

While ARRI endeavors to enhance the quality, reliability and safety of their products, customers agree and acknowledge that the possibility of defects thereof cannot be eliminated entirely. To minimize risk of damage to property or injury (including death) to persons arising from defects in the products, customers must incorporate sufficient safety measures in their work with the system and have to heed the stated canonic use.

ARRI or its subsidiaries do not assume any responsibility for incurred losses due to improper handling or configuration of the cforce mini lens motor or other system components.

ARRI assumes no responsibility for any errors that may appear in this document. The information is subject to change without notice.

For product specification changes since this manual was published, refer to the latest publications of ARRI data sheets or data books, etc., for the most up-to-date specifications. Not all products and/or types are available in every country. Please check with an ARRI sales representative for availability and additional information.

Neither ARRI nor its subsidiaries assume any liability for infringement of patents, copyrights or other intellectual property rights of third parties by or arising from the use of ARRI products or any other liability arising from the use of such products. No license, express, implied or otherwise, is granted under any patents, copyrights or other intellectual property right of ARRI or others.

ARRI or its subsidiaries expressly exclude any liability, warranty, demand or other obligation for any claim, representation, or cause, or action, or whatsoever, express or implied, whether in contract or tort, including negligence, or incorporated in terms and conditions, whether by statute, law or otherwise. In no event shall ARRI or its subsidiaries be liable for or have a remedy for recovery of any special, direct, indirect, incidental, or consequential damages, including, but not limited to lost profits, lost savings, lost revenues or economic loss of any kind or for any claim by third party, downtime, good-will, damage to or replacement of equipment or property, any cost or recovering of any material or goods associated with the assembly or use of our products, or any other damages or injury of the persons and so on or under any other legal theory.

In the case one or all of the foregoing clauses are not allowed by applicable law, the fullest extent permissible clauses by applicable law are validated.

## Contents

<b>1</b>	<b>For your safety.....</b>	<b>8</b>
<b>2</b>	<b>Audience and intended use.....</b>	<b>11</b>
<b>3</b>	<b>Scope of delivery and warranty.....</b>	<b>12</b>
<b>4</b>	<b>Introduction.....</b>	<b>13</b>
<b>5</b>	<b>Getting started.....</b>	<b>14</b>
<b>6</b>	<b>Layout.....</b>	<b>16</b>
<b>7</b>	<b>Control panel.....</b>	<b>18</b>
<b>8</b>	<b>Home screen.....</b>	<b>20</b>
<b>9</b>	<b>Main menu.....</b>	<b>22</b>
<b>10</b>	<b>Radio menu.....</b>	<b>23</b>
<b>11</b>	<b>Motor menu.....</b>	<b>24</b>
<b>12</b>	<b>Compatibility.....</b>	<b>25</b>
	<b>12.1 Sample configuration.....</b>	<b>26</b>

---

<b>13 Appendix.....</b>	<b>28</b>
13.1 Antenna connector.....	28
13.2 Specifications.....	28
13.3 Dimensions and weight.....	30
13.4 Pinouts.....	32
13.5 Software update.....	34
13.6 Cables and Accessories.....	37
13.7 Service contacts.....	38
13.8 International declarations.....	40

# 1 For your safety

Before use, please ensure that all users comprehensively read, understand, and follow the instructions in this document.

## Risk levels and alert symbols

Safety warnings, safety alert symbols, and signal words in these instructions indicate different risk levels:

### **DANGER!**

*DANGER* indicates an imminent hazardous situation which, if not avoided, **will result in** death or serious injury.

### **WARNING!**

*WARNING* indicates a potentially hazardous situation which, if not avoided, **may result in** death or serious injury.

### **CAUTION!**

*CAUTION* indicates a potentially hazardous situation which, if not avoided, **may result in** minor or moderate injury.



**NOTICE**

*NOTICE* explains practices not related to physical injury. No safety alert symbol appears with this signal word.

**Note:** Provides additional information to clarify or simplify a procedure.

**Vital precautions**** DANGER!****Risk of electric shock and fire!**

Short-circuits may entail lethal damage!

Before use, read and follow all valid instructions.

Use solely and exclusively as described in the instructions.

Never open. Never insert objects.

For operation, always use a power source as indicated in the instructions.

Always unplug the cable by gripping the plug, not the cable.

Never try to repair. All repair work should be done by a qualified ARRI Service Center.

Never remove or deactivate any safety equipment (incl. warning stickers or paintmarked screws).

Always protect from moisture, cold, heat, dirt, vibration, shock, or aggressive substances.

 **DANGER!****Risk of fire!**

Short-circuits and back currents to power supplies/batteries may entail lethal damage!

Always use original ARRI/cmotion LBUS cables to external power sources (D-Tap, XLR)! ARRI/cmotion LBUS cables to external power sources provide a protection circuit to prevent back currents to power supplies/batteries.

## 2 Audience and intended use

### ***NOTICE***

The product is solely and exclusively available for commercial costumers and shall be used by skilled personnel only. Every user should be trained according to ARRI guidelines. Use the product only for the purpose described in this document. Always follow the valid instructions and system requirements for all equipment involved.

The Active Motor Controller AMC-1 is solely and exclusively for use on professional camera setups.

### 3 Scope of delivery and warranty

#### **NOTICE**

Product and packaging contain recyclable materials. Always store, ship, and dispose of according to local regulations. ARRI is not liable for consequences from inadequate storage, shipment or disposal.

#### **Delivery**

On delivery, please check if package and content are intact. Never accept a damaged/ incomplete delivery. A complete delivery includes:

- Active Motor Controller AMC-1
- User manual
- Original packaging

#### **Warranty**

For scope of warranty, please ask your local ARRI Service Partner. ARRI is not liable for consequences from inadequate shipment, improper use, or third-party products.

## 4 Introduction

The ARRI Active Motor Controller AMC-1 is a compact motor controller with an LBUS interface that can connect with up to three daisy-chained cforce motors. It is designed for weight and size-critical setups such as Steadicam or aerial camera drones.



## 5 Getting started

This quick start guide walks you through setting up the AMC-1 with one hand unit and three cforce mini motors for wireless lens control.

### Mounting on camera

Mount the AMC-1 on the camera, preferably in a vertical position by using the L-Bracket, with the antenna pointing upwards and the LBUS connector pointing towards the lens. Such a position makes the AMC-1 user interface easily accessible.

### Powering up

Connect the AMC-1 to a power source with one of the power cables listed on page 37. The AMC-1 will power-up automatically when connected to the power source.

### Setting up motors

Attach a cforce mini motor for focus, iris and zoom to the lens. Make sure the motor is properly mounted to the respective lens axis and will not loosen up when operated.

Use an LBUS cable to connect the AMC-1 (LBUS connector) with the cforce mini motor next to it. Use a second LBUS cable to connect a second cforce mini motor with the first one in a daisy-chain manner. Do the same for the third cforce mini motor.

Assign the cforce mini motor to the lens scale it is attached to (see the cforce mini user manual for further instructions).

Press the CAL button of the AMC-1 Home screen or hold the cforce mini setup button for three seconds to calibrate the motors. You can also trigger calibration from the hand unit.

Press the MOTOR button of the AMC-1 Home screen to access the motor setup menu page. Set up the motor mounting side and torque for the respective lens axis. Side refers to the side of the lens the motor is mounted to (on support rods underneath the lens). Torque refers to the motor torque; a higher value means higher torque.

## Connecting to hand unit

Set the radio channel on the AMC-1. Press the RADIO soft button on the Home screen and select a channel. Press SET to activate the selected channel. Make sure that the selected radio channel is not already in use by another motor controller. Set the hand unit to the same radio channel (see the hand unit's user manual for further instructions).

Once connected, the number of connected hand units will change from 0 to 1 on the AMC-1 Home screen.

You are now ready to shoot.

## 6 Layout



- 1 Upper soft buttons
- 2 Setup display
- 3 Lower soft buttons
- 4 Swivel antenna
- 5 LBUS connector to cforce motors
- 6 LCS connector to hand units for hard-wired operation



- 7 CAM connector to camera for REC start/stop, tally and power supply

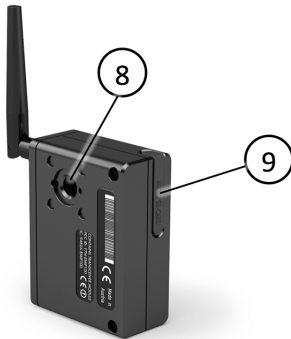

- 8 3/8-16 UNC mounting point
- 9 Micro SD card slot

## 7 Control panel

The AMC-1 features a user interface enabling the user to quickly configure the system. The 1.2" transfective LCD display shows vital status information and is easily readable in any ambient light conditions.



### Soft buttons

Four soft buttons are located above and below the display. They change their behavior depending on the screen content. Two rows at the top and the bottom of the screen show the function related to each button. Buttons without a label have no function in that screen.

## Menu navigation

Use the UP and DOWN soft buttons to navigate through the menu.

To access a new menu level, press the ENTER soft button. To go back, press the BACK or the HOME soft button.

Press SET to activate a setting.

## 8 Home screen

The Home screen is the default screen. It shows the current radio and motor status.

The Home screen provides four soft buttons:

CAL	Press to calibrate cforce lens motors.
MENU	Press to enter main menu.
RADIO	Press to select radio channel.
MOTOR	Press to enter motor setup menu.

The Home screen left side indicates the current radio status. The first line on the left indicates the current radio status as follows:

Off	Radio modem is switched off.
Initial.	Radio modem is initializing.
Ready	Radio modem is initialized and ready to connect.
Blocked	Another motor controller is already using the currently selected channel. Select another radio channel!

The second line on the left indicates the currently selected radio channel (0 - 7).

The third line on the left indicates the number of currently connected handsets (0 - 3).

The Home screen right side indicates the current status of the focus (F), iris (I) and zoom (Z) motors as follows:

None	No motor attached.
Idle	Motor is not assigned to a control device.
Ready	Motor is ready to use.
L, R	Indicates to which side of the lens the motor is set (Left/Right).

### **NOTICE**

A cforce motor must be calibrated under the following conditions:

- After connecting a cforce motor to the lens
- After changing lenses
- After a change of motor position while powered down

## 9 Main menu

The main menu contains parameters for the basic AMC-1 and motor setup.

### **Backlight**

Lets you set the backlight brightness of the LCD screen. The brightness can be set from 0 (backlight is off) to 10 (maximum brightness).

### **Firmware**

Lets you perform a software update for the AMC-1. Please read the update instructions on page 34.

### **cforce update**

Lets you perform a software update for cforce motors. Please read the update instructions on page 35.

### **System info**

Select the System Info menu page to identify the currently installed firmware version.

## 10 Radio menu

Press the RADIO button to enter the Radio menu page. Use the UP and DOWN soft buttons to select the radio channel or to switch the radio on and off. Select the same channel both on the hand unit and the AMC-1.

## 11 Motor menu

The motor menu lets you set up the cforce mini motors connected to the AMC-1.

### Axis

Use the AXIS button to select the motor (Focus, Iris or Zoom) you want to set up for torque and side.

#### **NOTICE**

The axis assignment is done through the setup button on the cforce mini motor itself.

### Torque

Press TORQUE to set the torque level from 1 (lowest torque) to 4 (highest torque).

### Side

Press SIDE to select the side on which the motor is mounted to the lens.



## 12 Compatibility

The AMC-1 is directly compatible with the following ARRI products:

- cforce mini lens motor
- Wireless Compact Unit WCU-4
- Single Axis Unit SXU-1
- Zoom Main Unit ZMU-3A
- Wireless Zoom Extension WZE-3 (white radio)
- Wireless Compact Unit WCU-3 (white radio)
- Wireless Main Unit WMU-3 (white radio)

The AMC-1 is directly compatible with the following cmotion products:

- cforce (classic) lens motor

### **NOTICE**

Setting the motor axis of a cmotion cforce (classic) lens motor is not possible via AMC-1.

## 12.1 Sample configuration



**NOTICE**

Some cameras do not supply the AMC-1 with enough power to drive three cforce motors at the same time. In this case, you may supply power from an additional power source through the unused cforce motor LBUS connector (e.g. K2.0006758 Cable LBUS to D-Tap 0.8m/2.5ft).

**⚠ DANGER!****Risk of fire!**

Short-circuits and back currents to power supplies/batteries may entail lethal damage!

Always use original ARRI/cmotion LBUS cables to external power sources (D-Tap, XLR)! ARRI/cmotion LBUS cables to external power sources provide a protection circuit to prevent back currents to power supplies/batteries.

## 13 Appendix

### 13.1 Antenna connector

The radio connection is established via the antenna connected to the antenna connector. Do not leave the connector open during operation or transport. The radio module inside could be damaged by electrostatic discharge via the open connector. We recommend using the originally supplied antenna only.

### 13.2 Specifications

#### Electrical data

Supply Voltage:	12 V to 34 V DC (full motor speed)
Current Consumption:	135 mA@12 V (radio on/ready)
	70 mA@24 V (radio on/ready)
Operating Temperature:	-20 to +50 °C (-4 to +122 °F)

## Radio system

The AMC-1 contains a radio unit that enables wireless lens control and lens data communication with a white coded radio module. A white ring at the base of the antenna mount point identifies it. It offers 8 channels to choose from:

<b>Channel</b>	<b>Frequency</b>
0	2.410 GHz
1	2.415 GHz
2	2.430 GHz
3	2.435 GHz
4	2.450 GHz
5	2.455 GHz
6	2.470 GHz
7	2.475 GHz

White radio and legacy yellow radio cannot be mixed in the same radio network of camera and hand units. It is possible to use both systems in parallel within different radio networks.

## 13.3 Dimensions and weight

### Dimensions

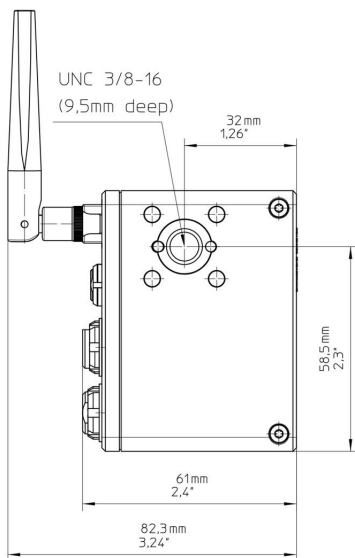

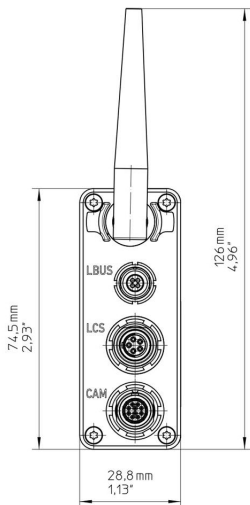

## Weight

Weight of Active Motor Controller AMC-1 (including antenna): 173g/6oz

## 13.4 Pinouts

### LBUS connector

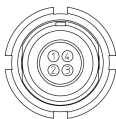

- 1 GND
- 2 CAN-L
- 3 V-BAT
- 4 CAN-H

### LCS connector

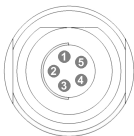

- 1 GND
- 2 n.c.
- 3 CAN-L
- 4 CAN-H
- 5 V-BAT



## CAM connector

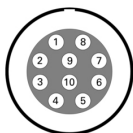

- |    |            |
|----|------------|
| 1  | GND        |
| 2  | V-BAT      |
| 3  | RxD RS-232 |
| 4  | TxD RS-232 |
| 5  | ARRI R/S   |
| 6  | RUN-SW2    |
| 7  | ACAM       |
| 8  | RUN-SW1    |
| 9  | DAC-CAM    |
| 10 | D-CAM      |

## 13.5 Software update

### AMC-1 software update

To keep your AMC-1 up-to-date, you may need to update its firmware. Please check ARRI's website for the latest firmware packages. To update the device, proceed as follows:

- 1 Go to the download area at [www.arri.com/ecs/amc-1](http://www.arri.com/ecs/amc-1).
- 2 Download the zip file containing `amc1_xxx.upd`, with `xxx` being the release version number.
- 3 Unzip the file.
- 4 Copy `amc1_xxx.upd` to the root directory of a Micro SD card.
- 5 Insert the Micro SD card in the Micro SD card slot of the AMC-1.
- 6 Select MENU>FIRMWARE. Update information appears.
- 7 Press both UPDATE keys simultaneously to start the update.
- 8 The AMC-1 will reboot after the update is completed.

 **WARNING!**

Do not switch power off and do not remove the Micro SD card during the update as this may damage the AMC-1!

## **cforce mini software update**

To keep cforce motors up-to-date, you may need to update their firmware. The Active Motor Controller AMC-1 offers cforce motor update functionality. Please check ARRI's website for the latest firmware packages. To update a cforce mini motor via AMC-1, proceed as follows:

- 1 Go to the download area at [www.arri.com/ecs/cforce\\_mini](http://www.arri.com/ecs/cforce_mini).
- 2 Download the zip file containing `cforce_xxx.cmf`, with xxx being the release version number.
- 3 Unzip the file.
- 4 Copy `cforce_xxx.cmf` to the root directory of a Micro SD card.
- 5 Connect one cforce motor to the AMC-1 LBUS connector.
- 6 Insert the Micro SD card in the Micro SD card slot of the AMC-1.

- 7 Select MENU>CFORCE UPDATE. Update information appears.
- 8 Select MAIN (DEFAULT) update mode.
- 9 Press UPDATE to start the update. The cforce mini status LED will light blue during the update. Wait until the message "Update completed" appears on the AMC-1 screen.
- 10 Press HOME to return to the Home screen.

**NOTICE**

You can only update one cforce motor at a time.

** WARNING!**

Do not switch power off and do not remove the Micro SD card during the update as this may damage the cforce motor!

## 13.6 Cables and Accessories

The following accessories are compatible with the AMC-1:

- K2.0001996 Swivel antenna for SMC-1 and EMC-1 Motor Controllers
- K2.0001606 Cable SMC/EMC/AMC to RS
- K2.0002682 Cable SMC/EMC/AMC to D-Tap
- K2.0001999 Cable SMC/EMC/AMC to LANC/D-Tap
- K2.0001997 Cable SMC/EMC/AMC to Sony F5/55
- K2.0001998 Cable SMC/EMC/AMC to RED EPIC/D-Tap
- K2.0002727 Cable SMC/EMC/AMC to PSC
- K2.0002725 Cable SMC/EMC/AMC to open end
- K2.0001967 L-Bracket
- K2.0001758 V-Plate

## 13.7 Service contacts

### **Munich, Germany**

Arnold & Richter Cine  
Technik

+49 89 3809 2121

service@arri.de

Business hours:

Mo. - Fr. 9:00 - 17:00  
(CET)

### **London, Great Britain**

ARRI CT Limited

+44 1895 457 051

service@arri-ct.com

Business hours:

Mo. - Thu. 9:00 -  
17:30

Fr. 9:00 - 17:00  
(GMT)

### **Burbank, USA**

ARRI Inc. West Coast

+1 877 565 2774

service@arri.com

Business hours:

Mo. - Fr. 8:15 - 17:00  
(PST)

### **Vienna, Austria**

ARRI Cine + Video  
Geräte Ges.m.b.H.

+43 1 8920107 30

service@arri.at

Business hours:

Mo. - Fr. 9:00 - 17:00  
(CET)

### **Milan, Italy**

ARRI Italia S.r.l.

+39 (02)262 271 75

info@arri.it

Business hours:

Mo. - Fr. 9:00 - 18:00  
(CET)

### **New York, USA**

ARRI Inc. East Coast

+1 877 565 2774

service@arri.com

Business hours:

Mo. - Fr. 8:00 - 17:30  
(EST)

**Mississauga, Canada**

ARRI Canada Limited

+1 416 255 3335

service@arri.com

Business hours:

Mo. - Fr. 8:30 - 17:00  
(EDT)**Hong Kong, China**

ARRI Asia Limited

+852 2537 4266

service@arriasia.hk

Business hours:

Mo. - Fr. 10:00 -  
18:30 (HKT)**Beijing, China**

ARRI China Co. Limited

+86 10 5900 9680

service@arri-china.com

Business hours:

Mo. - Fr. 9:00 - 18:00  
(CST)**Sydney, Australia**

ARRI Australia Pty Ltd

+61 2 9855 4305

service@arri.com.au

Business hours:

Mo. - Fr. 8:00 - 18:00  
(AEST)

## 13.8 International declarations

### EC Declaration of Conformity

The product Active Motor Controller AMC-1 conforms with the specifications of the following European directives:

- Directive 2014/30/EU of the European Parliament and the Council of 26 February 2014 on the harmonization of the laws of the Member States relating to electromagnetic compatibility
- Directive 1999/5/EU of the European Parliament and the Council of 9 March 1999 on radio equipment and telecommunications terminal equipment and the mutual recognition of their conformity
- Directive 2011/65/EU of the European Parliament and the Council of 8 June 2011 on the restriction of the use of certain hazardous substances in electrical and electronic equipment

The compliance with the requirements of the European Directives was proved by the application of the relevant harmonized standards.



## **FCC Class A Statement**

Note: This equipment has been tested and found to comply with the limits for a Class A digital device, pursuant to Part 15 of the FCC Rules. These limits are designed to provide reasonable protection against harmful interference when the equipment is operated in a commercial environment. This equipment generates, uses, and can radiate radio frequency energy and, if not installed and used in accordance with the instruction manual, may cause harmful interference to radio communications. Operation of this equipment in a residential area is likely to cause harmful interference in which case the user will be required to correct the interference at his own expense.

## **Industry Canada Compliance Statement**

Complies with the Canadian ICES-003 Class A specifications. Cet appareil numérique de la Classe A est conforme à la norme NMB-003 du Canada. This device complies with RSS 210 of Industry Canada. Cet appareil est conforme à CNR-210 d' Industrie Canada. This Class A device meets all the requirements of the Canadian interference-causing equipment regulations. Cet appareil numérique de la Classe A respecte toutes les exigences du Règlement sur le matériel brouilleur du Canada.

## **Japan MIC Statement**

Complies with Ministry of Internal Affairs and Communications notification Article 88, Annex 43.

## **Radio Module**

The Active Motor Controller contains the following radio module:

FCC ID: Y7N-EMIP300

IC ID: 9482A-EMIP300

MIC ID: 011-150023