

SkyLink Base Station and Receiver

USER GUIDE

L5.0019058



© 2018 Arnold & Richter Cine Technik GmbH & Co. Betriebs KG.

All rights reserved. Information subject to change without notice. ARRI and all affiliated companies disclaim liability for any injury, damage, direct or indirect loss, consequential or economic loss or any other loss occasioned by the use of, inability to use or reliance on the information contained in this document.

No part of this document may be used for distribution, reproduction, transmission, transcription, storage in a data retrieval system, or translated into any language in any form by any means without the prior written permission of ARRI®. If you are downloading files from our web pages for your personal use, make sure to check for updated versions. ARRI® cannot take any liability whatsoever for downloaded files, as technical data are subject to change without notice.

Art-Net™ Designed by and Copyright Artistic Licence Holdings Ltd.

CRMX™ is a trademark of LumenRadio AB.

ARRI, ARRI ARRI, the ARRI Logo, ARRIMAX, ARRISUN, EB, EBB, L-Series, MAX Technology, M-Series, POCKETPAR, True Blue, SkyPanel, SKYPANEL, T 12 and T 24 are registered trademarks of Arnold & Richter Cine Technik GmbH & Co. Betriebs KG.

Dimensions

Base Station

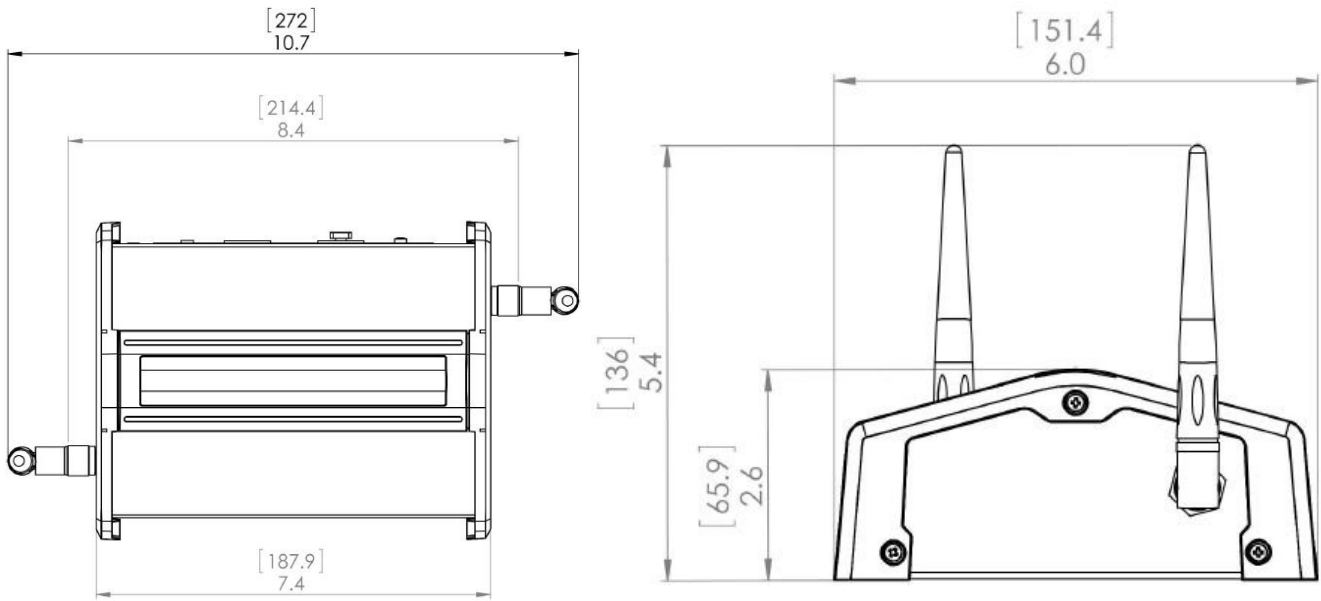

Receiver

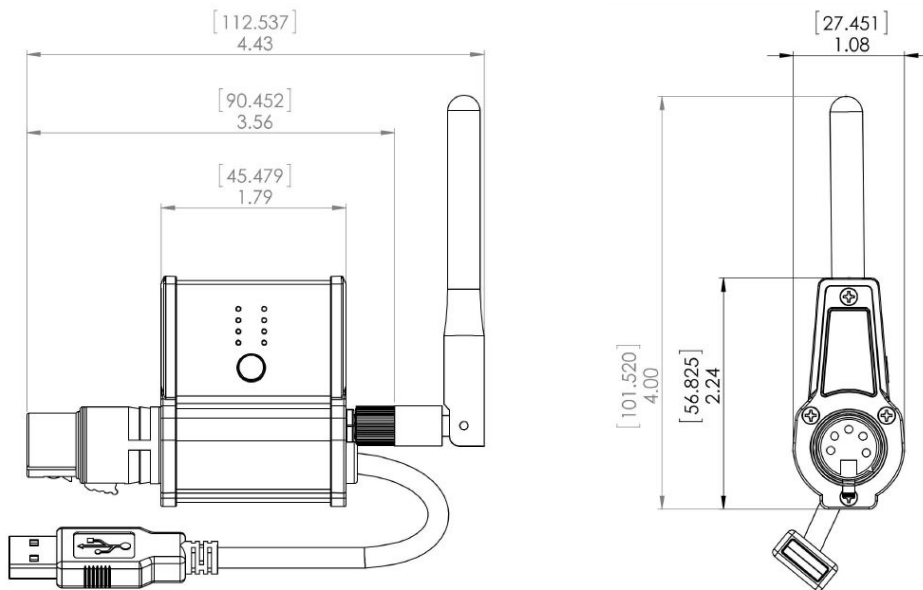

Content

Dimensions	3
Content	4
Safety Information	5
Introduction	6
Product Layout	7
Set Up	9
General Operation	10
Configuration	12
Troubleshooting	17
Specification	18

Safety Information

Intended Use

This product is intended to transmit and receive lighting control data in a dry environment.

Always follow the safety information.

Any usage other than described above is not permitted and can damage the product and lead to associated risks such as short-circuit, fire, electric shock, etc. You are not allowed to modify the product.

This product fulfills national and international requirements.

Warnings

WARNING!

Humidity and Condensation! Risk of electric shock and fire.

Never expose the product to rain or moisture. Do not use the product for 2 h when it was exposed to big temperature differences as condensed moisture may damage the product electrically when switched on.

Always place the SkyLink base station on an even, stable surface to prevent it against falling.

Never cover the SkyLink base station nor the SkyLink receiver during operation. Keep a minimum clearance of 0.1 m (3.9 in.) around the housing.

Avoid direct illumination by other luminaires or other heat sources.

Check the mains cable and connector cable prior to every operation for damage.

In case of visible damage to the mains cable or the housing, the device must not be operated any longer. Damaged components must be replaced by an ARRI service center.

General Notes

NOTICE

The SkyLink system is intended for professional use and may only be operated by qualified persons.

Please read these instructions carefully before using the product for the first time. The following text contains important information for safe handling.

For your personal safety, please observe the safety instructions and warnings.

Observe all common and local safety regulations.

Block access below the work area and work from a stable platform whenever installing, servicing or moving the product or accessories.

Please keep these instructions for possible subsequent owners.

Please dispose the packing material at your local recycling center for environmental protection.

Defective products shall be disposed appropriately. For further information please ask your ARRI dealer or your local authorities.

Use only original ARRI spare parts and accessories.

Introduction

Thank you for selecting the SkyLink wireless communication system from ARRI. The SkyLink is a portable, all-in-one wireless solution utilizing WiFi, Ethernet, or DMX to connect your mobile phone, tablet, PC, or console seamlessly to the SkyPanel family and many other fixtures.

SkyLink leverages the industry-leading CRMX wireless protocol by LumenRadio for robust, efficient communication with lighting fixtures over distances about 500 m (1.640 ft) and provides capability for two-way RDM communication, allowing advanced management and configuration of SkyPanels without ever laying a single data cable.

Features

Versatility

SkyLink is a two-part system that allows for wireless DMX and RDM communication to SkyPanels. The SkyLink Receiver and the SkyLink Base Station use LumenRadio CRMX for DMX/RDM communication and WiFi in the SkyLink Base Station allows for direct control from a DMX control application on a mobile device or computer. The SkyLink system can replace DMX data cables which saves time and money on set.

Connectivity

The SkyLink system incorporates a full-featured WiFi/Network router which can act as a centralized hub for lighting data networks. An XLR port on the SkyLink Base Station provides DMX input/output. The DMX signal from the SkyLink Receiver can be daisy-chained to multiple fixtures and communicate with both DMX and RDM.

Reliability

Utilizing the popular CRMX protocol by LumenRadio, SkyLink provides an encrypted, error-corrected signal linking fixtures with a robust connection even in the trickiest radio environments.

Properties

Antennas

The SkyLink wireless system comes with two RP-SMA 2dBi antennas for the SkyLink Base Station, and one RP-SMA 2dBi antenna for each SkyLink Receiver. An optional RP-SMA Range Extender kit is available.

Power Supply

The SkyLink Base Station uses the included 12V power supply. The SkyLink Receiver is powered through the USB-A tail, which plugs into the USB port below the **DMX IN** port on the ARRI SkyPanel.

Swivel XLR

The SkyLink Receiver can swivel 180° to best fit your fixture. Simply turn the connector for best fit.

Control

The SkyLink can be controlled over Art-Net or sACN from any mobile phone, tablet, or computer with appropriate DMX control software. SkyLink is fully RDM compatible and can wirelessly relay RDM commands and requests to and from fixtures.

Configuration Options

The SkyLink Base Station can be configured via an easily accessible web portal. CRMX Link/Unlink actions can be done both remotely in the web interface or locally via a physical Link button.

Product Layout

Overview of SkyLink Base Station

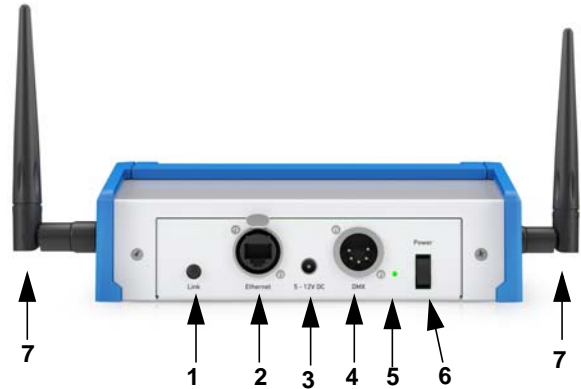
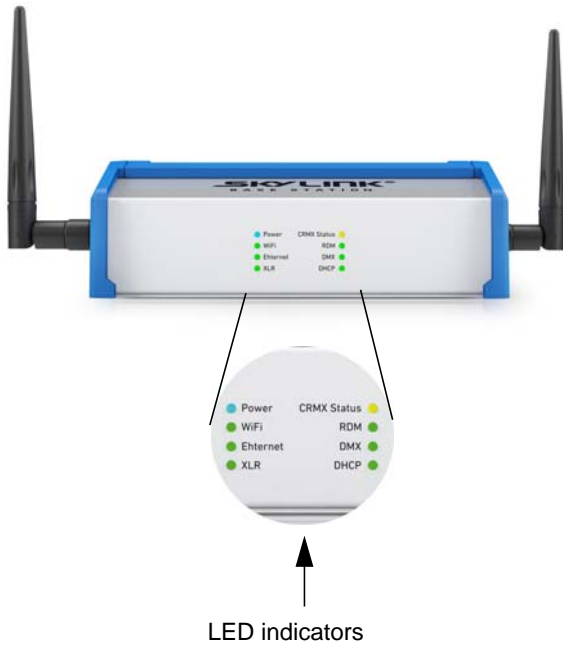

- 1 - Link button
- 2 - Ethernet connector
- 3 - Power input (12 VDC)
- 4 - DMX connector
- 5 - Reset pinhole
- 6 - Power switch
- 7 - Antenna

LED Indicators on the Front

LED	Indication when lit
Power	The SkyLink Base Station is receiving power and switched on.
WiFi	A networked device is currently connected to WiFi.
Ethernet	Presence of an Ethernet port connection.
XLR	The SkyLink Base Station is accepting DMX input from local XLR port instead of remote Art-Net/sACN from either Ethernet or WiFi.
CRMX Status	Operation of CRMX transmitter. Usually solid, blinks when linking.
RDM	Indicates RDM traffic.
DMX	Indicates DMX traffic.
DHCP	The SkyLink Base Station's DHCP service is assigning IP addresses to Ethernet and WiFi devices.

Connectors and Switches on the Back

Feature	Description
Link Button	Links or unlinks receivers. Short press to link, hold 3 s to unlink all.
Ethernet	Standard RJ-45 Ethernet connector, EtherCON compatible. For use with Art-Net and sACN communication.
12 V DC Input	Power Input - 2.1mm x 5.5mm Barrel (Center Positive).
DMX	5 Pin XLR Female. Default DMX OUT, can be configured from web interface.
Reset Pinhole	Reset SkyLink Base Station to factory default settings.
Power switch	Switches the unit on or off.
Antenna	For transmitting DMX/RDM WiFi Data.

Overview of SkyLink Receiver

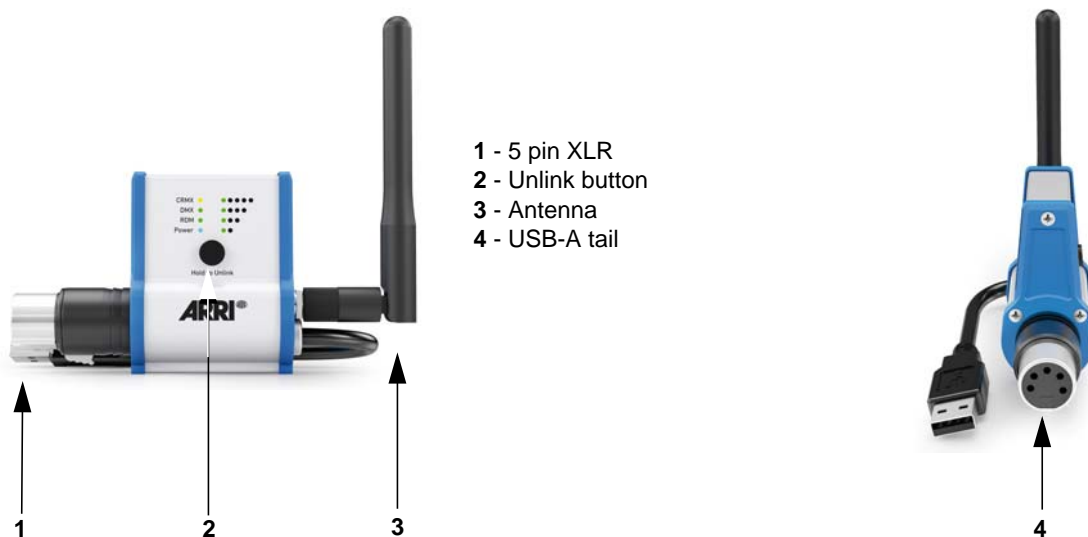

LED Indicators

LED	Indication when lit
CRMX	Indicates CRMX Status. Solid if Linked, Flashes if Linking or No Signal
DMX	Valid DMX signal.
RDM	RDM Activity
Power	SkyLink Receiver is powered on
oooo	80% Signal Strength or greater
ooo	60% Signal Strength or greater
oo	40% Signal Strength or greater
o	20% Signal Strength or greater

Connectors and Switches

Feature	Description
5 Pin XLR	Attaches to any standard 5 Pin DMX XLR port. Swivels 180° to fit anywhere.
Unlink Button	Hold to Unlink the receiver from the SkyLink Base Station.
Antenna	2dBi Antenna attached to RP-SMA Connector
USB-A Tail	Connects to a standard USB port for 5V DC power.

Set Up

Choosing a Location

Place the SkyLink Base Station on a stable surface, clear of obstructions. It is recommended that the unit be elevated above nearby objects and people to minimize physical interference. Do not place SkyLink Base Station in location that could result in injury or damage as a result of a fall.

Plug in SkyLink Base Station

Attach the included power supply into the 12 V DC barrel connector input on the rear of the SkyLink Base Station. Attach the included NEMA 5-15P (USA) or Schuko (Europe) power cable to the power adapter, then plug it into an AC power receptacle. The SkyLink power supply is compatible with voltages ranging from 100V-240VAC.

Plug in SkyLink Receiver

Simply plug the SkyLink Receiver into the DMX IN port on your ARRI SkyPanel or other DMX capable fixture. The XLR connector can swivel 180° to provide necessary clearance. Plug the USB-A tail into the USB port below the DMX IN on your SkyPanel to provide power. Check, if the USB mode of the SkyPanel is set to „Normal“. Otherwise the SkyLink Receiver is not powered and will not work.

Power On

Flip the Power switch downward to power on the SkyLink Base Station. The unit will power on and be ready within 10 seconds.

Connect to SkyLink Base Station

You can now connect to the ARRI SkyLink system using WiFi, Ethernet, or DMX. See how in the section “General Operation” on page 10.

General Operation

Connect

To log in to the ARRI SkyLink Base Station, first connect to the WiFi network on your control device. Find the ARRI SkyLink Base Station in your list of networks and join it. Enter the password when requested.

Default SSID	ARRI SkyLink Base Station
Default Password	ArriSkyLink

NOTICE

Please note that the passwords are case sensitive.

For more information on WiFi configuration and using the ARRI SkyLink via Ethernet in a network, see “Set Up” on page 9.

Linking

After ensuring your SkyLink Receivers are powered and unlinked, briefly press the **Link** button on the back of your SkyLink Base Station. The **Status** light on your SkyLink Receivers will blink for several seconds in unison with the **CRMX Status** light on the SkyLink Base Station. Linking is complete when flashing stops.

The SkyLink Base Station can be linked to an unlimited number of SkyLink Receivers.

NOTICE

Receivers will stay linked to their transmitter indefinitely unless unlinked. For more information, see “Unlinking” on page 11.

Light Operation

Now that your tablet or device is connected and your receivers are linked, open your Art-Net or sACN compatible DMX lighting control app. In most cases, use these default settings:

IP Address	192.168.0.100
Protocol	Art-Net
Universe	0
Sub Net	0

The SkyLink Base Station is capable of receiving a single DMX universe of 512 DMX channels.

Operating Range

The SkyLink has a range of about 500 m (1.640 ft) over CRMX. External factors, such as walls, vegetation, or even people in between the Base Station and Receiver can severely degrade the range. Best practice is to have an uninterrupted line-of-sight (LOS) between the SkyLink Base Station and the SkyLink Receiver.

Unlinking

Unlink One Receiver

On the SkyLink Receiver, press and hold its Unlink button for more than 3 seconds to unlink it from a transmitter. The CRMX indicator will extinguish.

Unlink All Receivers

On the SkyLink Base Station, press and hold the Link button for more than 3 seconds to unlink all receivers currently paired with the SkyLink Base Station.

Factory Reset

Follow these steps to restore the SkyLink Base Station to factory default settings:

- Turn the Power switch of the SkyLink Base Station to the Off position

While holding the RESET in with a pen, turn the SkyLink Base Station Power switch On. Hold the RESET button for at least 10 seconds. .

NOTICE

The RESET button can be found between DMX IN and the power switch on the rear of the SkyLink Base Station.

Configuration

Web Portal

All configuration of the ARRI SkyLink Base Station can be done through its integrated web portal.

To access the web portal:

1. Connect to the SkyLink Base Station WiFi or Ethernet port.
2. Open web browser on computer or mobile device.
3. Enter the IP address of the SkyLink Base Station into the URL box of the web browser.
(Default IP address is 192.168.0.100)

Status Page

The Status Page of the SkyLink Web Portal will give device information and allow for adjustment of device name and factory reset.

Device Information

States the model description of the device and the RDM UID.

Box Name

Allows the user to set the name of the Base Station which will also be used as the WiFi SSID.

Factory Reset

Allows the user to perform a factory reset which will restore all the device settings to their original factory defaults. A factory reset can also be performed by holding the RESET button on the rear for 10 seconds while powering up.

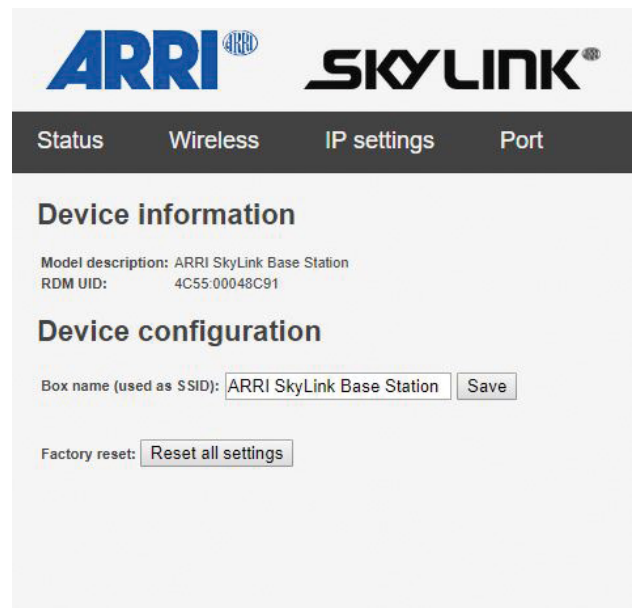

Wireless Page

The Wireless Page allows the user to configure several settings related to the wireless radios in the SkyLink Base Station.

CRMX Output Power

Allows the user to set the power output of the LumenRadio CRMX radio. Higher output power can increase CRMX range, but may reduce effective WiFi range in some situations. Options are:



Minimum	Outputs 5mW , suitable for small sized locations.
Low	Outputs 25 mW , suitable for medium sized locations.
Normal	Outputs 100 mW , suitable for large sized locations.
High (FCC Mode)	Outputs 125 mW , suitable for locations with many obstructions.

NOTICE

High (FCC Mode) output setting is only allowed for locations within the United States of America. This mode is prohibited in locations outside of the USA.

Click “Save” after a change is made to store your new setting.

CRMX Link

Allows user to Link or Unlink all CRMX receivers powered on and in range of the SkyLink Base Station.

WiFi

Allows user to set the WiFi channel (1 through 11). Refer to the section on **RF Management** for more details about selecting an operating channel in environments with multiple WiFi networks.

Click “Save” after a change is made to store your new setting.

SSID

This is the name of the WiFi network. The user can change this name to any they would like.

Click “Save” after a change is made to store your new setting.

Password

The user can set a custom password for the SkyLink Base Station WiFi network. The default password is “ArriSkyLink”. Please note that passwords are case sensitive.

Click “Save” after a new password is set to store your new setting.

IP Settings Page

The IP Settings Page allows users to configure different settings in relation to IP (Internet Protocol) attributes.

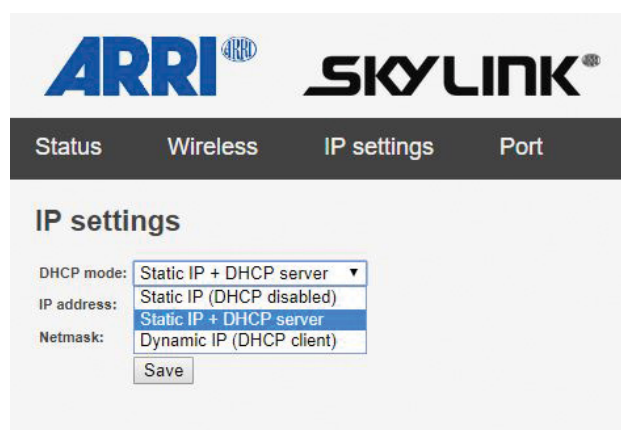

DHCP Mode

Static IP (DHCP disabled)	The SkyLink Base Station will have a static IP address and will not generate IP addresses for connected devices.
Static IP + DHCP Server	The SkyLink Base Station will have a static IP address and will also generate IP addresses for connected devices.
Dynamic IP (DHCP Client)	The IP address of the SkyLink Base Station and other IP devices on the network will be set by a third party device (such as a network router).

Click “Save” after a change is made to store your new setting.

IP Address

This is the IP address you will use to communicate with the SkyLink Base Station. It can be adjusted and set by the user. The default IP address is 192.168.0.100.

Click “Save” after a change is made to store your new setting.

Netmask

A netmask is a method for dividing an IP address into subnets and specify the network’s available hosts. The netmask can be configured by the user. The default netmask is 255 . 255 . 255 . 0 .

Click “Save” after a change is made to store your new setting.

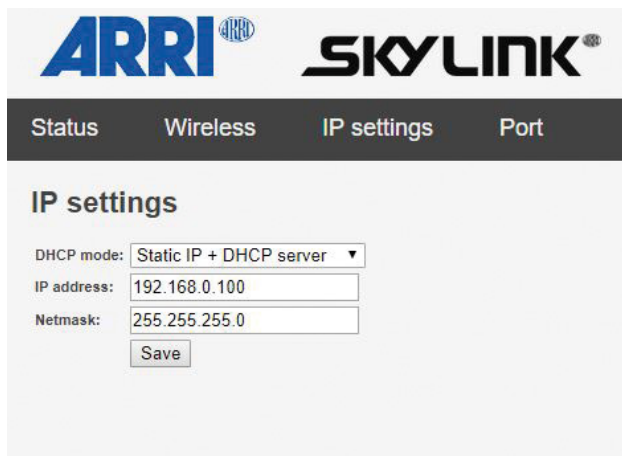

Port Page

The Port Page allows the user to configure which port the DMX/RDM source is coming from and which protocol is used to transmit DMX/RDM data to the SkyLink Receivers.

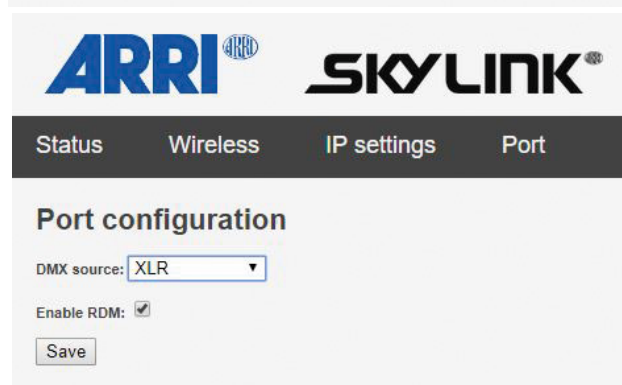
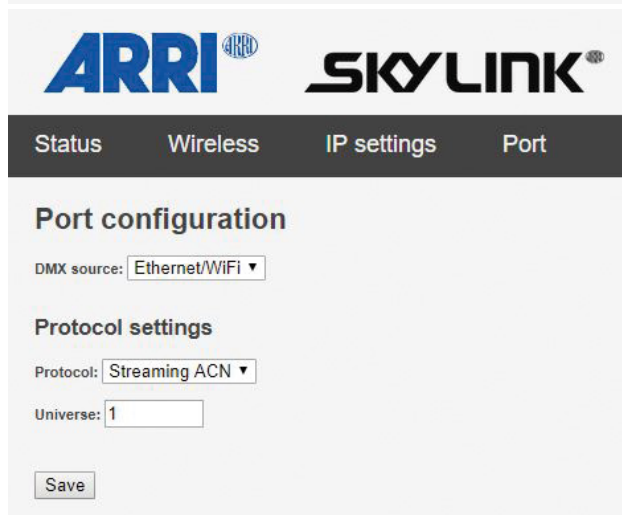
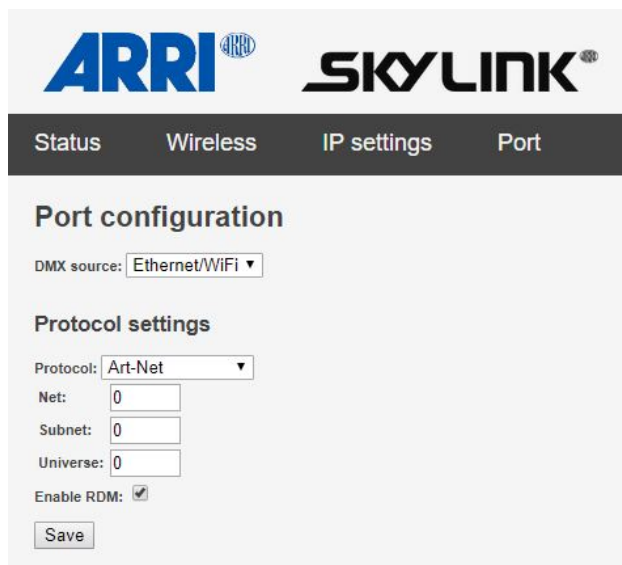

DMX Source

XLR	The SkyLink Base Station is using the data from the 5-Pin XLR port as the control signal.
Ethernet/WiFi	The SkyLink Base Station is using the data from the Ethernet port and the WiFi radio as the control signal.

Your SkyLink Base Station can receive DMX over Ethernet from either Art-Net or sACN sources. Choosing which network protocol to use on your network will depend on the capabilities of your DMX controller as well as other devices in your lighting network.

Protocol Settings

- Art-Net: Allows a Net, SubNet, and Universe of the Art-Net network to be set. Also allows for the enabling and disabling of the RDM communication.
- sACN (Streaming ACN): Allows for the Universe of the sACN network to be set.

RDM

ARRI SkyLink is fully RDM compatible and can receive commands from any RDM-enabled software or console over Art-Net or DMX (5-pin XLR). Ensure that “Enable RDM” is checked in the “Ports” page of the Web Portal. Fixtures such as ARRI SkyPanels or L-Series can then be easily configured.

Click “Save” after a change is made to store your new setting.

Advanced Connection Options

In addition to acting as a WiFi access point, the ARRI SkyLink Base Station has several other ways of controlling and connecting to the Base Station.

Ethernet

If your location is in a crowded wireless area, the WiFi radio on the SkyLink Base Station may not perform to its best capabilities. The Ethernet port on the Base Station provides another connection option. A mobile device or computer can connect with wired Ethernet for a more robust and direct connection to the SkyLink Base Station. The integrated WiFi access point can be used in conjunction with wired Ethernet for multi-node systems.

5-Pin XLR In

ARRI SkyLink can optionally be controlled directly through the 5-pin XLR DMX port. Choose DMX Source: “XLR” on “Port” page. This will allow for a control device, such as a professional lighting console, to be connected directly to the SkyLink Base Station. Full RDM functionality is available via DMX In.

5-Pin XLR Out

In Ethernet/WiFi mode, the 5-pin XLR port will broadcast the same active DMX universe used by the wireless CRMX signal. This allows for a wired network of fixtures using standard 5-pin DMX cables to be used at the same time as the wireless CRMX network. A male-female adapter may be required.

DMX Multi-Universe Networks

If several universes are required, several SkyLink Base Stations can be set to different universe numbers and connected together using a network switch. Each SkyLink Base Station can control different sets of SkyLink Receivers.

SkyLink Receivers will need to be Linked to the individual SkyLink Base Stations at different times. To Link the first DMX Universe, power on *only* the SkyLink Receivers you wish to be associated with that Universe. Then press the Link button on the back of the first DMX Universe Base Station. Repeat this process for the other DMX Universes.

The DMX universe can be configured in the SkyLink Base Station web portal under the „Ports“ tab.

RF Management

Selecting a WiFi Channel

The 2.4 GHz WiFi band is divided into 11 channels. Because WiFi channels overlap each other there are a reduced number of channels available to minimize interference from surrounding WiFi networks. Using channels 1, 6 or 11 whenever possible will help provide the most reliable WiFi signal strength while minimizing interference.

A WiFi analyzer can be used to determine the unused channels.

Antenna placement

Each SkyLink Base Station is supplied with 2 bi-polar antennas and each SkyLink Receiver is supplied with 1 omnidirectional antenna. Viewed from the front, the Arri SkyLink Base Station's left antenna handles CRMX, and the right handles WiFi.

For maximum range, the SkyLink Base Station CRMX and Receiver antennas should be oriented in the same direction, and all devices should have an uninterrupted line-of-sight between them. The WiFi and CRMX antennas should not be parallel, but off-angle from each other.

If WiFi signal problems such as lag or choppy DMX performance persist, it may be necessary to adjust the position of the two antennas on the SkyLink Base Station. Tilting the antennas perpendicular to each other or utilizing the optional Range Extender kit can enhance the distance of the WiFi signal.

If using other wireless transmission devices, such as other wireless DMX units or WiFi routers, it is important to maintain a minimum of 5 meters distance between devices for optimum performance of both systems.

Interference

In many environments where multiple 2.4 GHz systems are in place, it can be beneficial to coordinate a frequency-use plan with other responsible parties.

In extremely crowded wireless environments you may experience connection problems with WiFi without suffering from CRMX performance loss. In these tough environments you can continue to use the robust CRMX capabilities of your SkyLink Base Station by connecting your DMX controller app/device to the SkyLink Base Station with an Ethernet cable.

Troubleshooting

Problem	Probable cause(s)	Remedy
Base Station and Receivers appear linked or connected, but control cannot be established	Wrong port selected	Ensure proper port is selected in the Base Station web portal (e.g., Ethernet/WiFi or XLR).
	IP settings wrong	If using Ethernet, ensure all Protocol, Sub-Net, Universe settings are correct and matching your control device settings. (Note: Default is Art-Net, Net 0, Sub-Net 0, Universe, 0)
	Receiver(s) not linked to Base Station	Double check that receivers are linked to Base Station.
Receiver is unable to link or has intermittent signal	Receiver linked to other transmitters	Ensure that Receiver is unlinked from other transmitters by using "Hold to Unlink" button for 3 seconds. Press "Link" button on your Base Station once to try again.
	Adjustment of WiFi antenna insufficient	Adjust WiFi antenna angle to be parallel with Base Station CRMX antenna.
	No line of sight between transmitter and receiver	Move Base Station or Receiver to be clear of obstructions. Optional Range Extender Kit can also be used to elevate antenna.
	To less power of Base Station signal	Increase Base Station CRMX output power. (Note: requires restart, may affect WiFi range)
WiFi performance is intermittent	Control device not logged in	Ensure the control device is logged into SkyLink Base Station's WiFi network
	Distance to control device too big	Move the control device closer to the SkyLink Base Station.
	Adjustment of SkyLink Base station antenna insufficient	Adjust SkyLink Base Station antennas. WiFi has greater range if antennas are perpendicular.
	Weak signal	Use Optional Range Extender Kit to elevate WiFi antenna above obstructions.
	CRMX output power too high	Decrease CRMX output power. (Note: requires restart, may affect CRMX range)
ARRI SkyLink Base Station appears to be causing interference with other devices	Interfering device close to Base Station	Move the Base Station and interfering device away from each other.
	CRMX output power too high	Lower the CRMX Output Power in the Wireless page of the Base Station Web Portal.
	Interference of WiFi channels	Change the WiFi channel of the Base Station in the Wireless page of the Base Station Web Portal.
	Art-Net / sACN source is not in unicast mode	Ensure your Art-Net/sACN source is in Unicast mode to minimize WiFi rebroadcast.

Specification

SkyLink Receiver

Wireless Communication	LumenRadio CRMX (DMX/RDM) Receiver
Range	CRMX up to 500 m (1.640 ft)
Frequency Range	2.404 - 2.480 MHz
Weight	0.1 kg / 0.22 lbs
Protocols	DMX-512(A) and RDM ANSI E1.20
Voltage Input	5 V DC
Power Connector	Male USB-A
Antenna Connector	RP-SMA Female
DMX Connector	XLR 5-pin Female with 180° rotation
Control	„Unlink“ Button for disconnecting from CRMX network
Remote Device Management (RDM)	DMX Setup and Standard RDM commands
Housing Color	Blue / Silver
Ambient Temperature Operation	-20 to +50° C (-4 to 122° F)
Protection Class / IP Rating	III / IP20
Certifications	CE, FCC

SkyLink Base Station

Wireless Communication	LumenRadio CRMX (DMX/RDM) Transmitter and WiFi
Range	CRMX up to 500 m (1.640 ft) WiFi up to 75 m (246 ft)
Frequency Range	2.404 - 2.480 MHz
Protocols	DMX-512(A), RDM ANSI E1.20, Art-Net, sACN
DMX Connector	XLR 5-pin Female
DMX Universe Support	One universe with 512 channels
Ethernet	EtherCON RJ45 Female
Antenna Connector	Two RP-SMA Female
Antenna Type	2x2 dBi RP-SMA antenna
Control	„Link“ Button for linking to CRMX devices Webpage interface for adjusting settings
Power Supply Input Range	100 to 240 V ~, 50/60 Hz
Power Supply Output Range	12 V DC
Power Input Connector	2.1 x 5.5 mm Barrel connector
Device Input Voltage	12 V DC
Weight	1.5 kg / 3.3 lbs
Housing Color	Blue / Silver
Ambient Temperature Operation	-20 to +50° C (-4 to 122° F)
Protection Class / IP Rating	III / IP20
Certifications	CE, FCC

The antenna(s) used for this transmitter must be used to provide a separation distance of at least 20 cm from all persons and must not be co-located or operating in conjunction with any other antenna or transmitter.

This equipment has been tested and found to comply with the limits for a Class B digital device, pursuant to part 15 of the FCC Rules. These limits are designed to provide reasonable protection against harmful interference in a residential installation. This equipment generates, uses and can radiate radio frequency energy and, if not installed and used in accordance with the instructions, may cause harmful interference to radio communications. However, there is no guarantee that interference will not occur in a particular installation. If this equipment does cause harmful interference to radio or television reception, which can be determined by turning the equipment off and on, the user is encouraged to try to correct the interference by one or more of the following measures:

- Reorient or relocate the receiving antenna.
- Increase the separation between the equipment and receiver.
- Connect the equipment into an outlet on a circuit different from that to which the receiver is connected.
- Consult the dealer or an experienced radio/TV technician for help.

ARRI 